

# Robust Multi-Objective Control for Linear Systems

OLOCEP project (RoMulOC + GloptiPoly)

LAAS-CNRS, Toulouse, FRANCE

Denis Arzelier & Didier Henrion & Jean Lasserre & Dimitri Peaucelle

Part-time engineer : Philippe Spiesser

## Large variety of considered problems

- Various performance specifications: stability, pole location,  $H_\infty$ ,  $H_2$ , Impulse-to-peak
- Structured parametric uncertainties: Affine polytopic & LFT
- Analysis and Design (SF, DOF, SOF...)

## Free and easy to use software

- Matlab toolbox - 'control toolbox' like
- YALMIP-based : many SDP solvers
- Reasonable computation time for realistic small problems

## Up-to-date Theoretical results

- Methods: Lyapunov, S-procedure, Finsler lemma, Topologic Separation...
- PDLF results based on elimination lemma
- Open to contributors

$\Delta$  : parametric uncertainty, assumed constant, belongs to a set  $\Delta$ .

$$s x(t) = A(\Delta)x(t) + B_w(\Delta)w(t) + B_u(\Delta)u(t)$$

$$z(t) = C_z(\Delta)x(t) + D_{zw}(\Delta)w(t) + D_{zu}(\Delta)u(t)$$

$$y(t) = C_y(\Delta)x(t) + D_{yw}(\Delta)w(t) + D_{yu}(\Delta)u(t)$$

Find controller  $K$  that fulfills robust specifications  $\Pi_i$  defined for models  $\Sigma_i(\Delta_i)$  with  $\Delta_i \in \Delta_i$ .

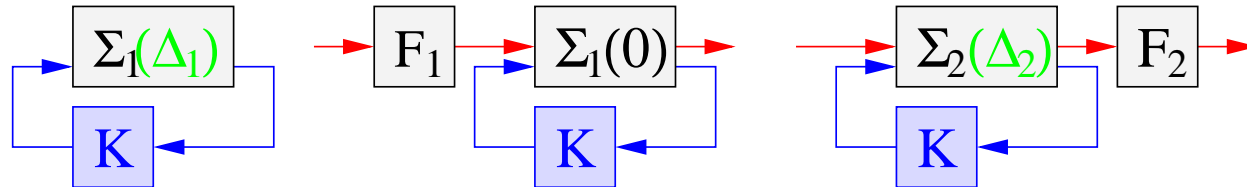

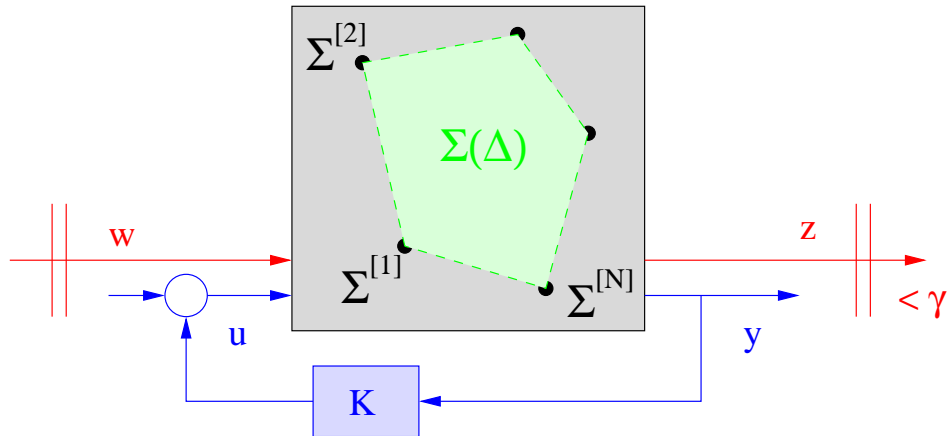

**Polytopic**

including interval and parallelotopic

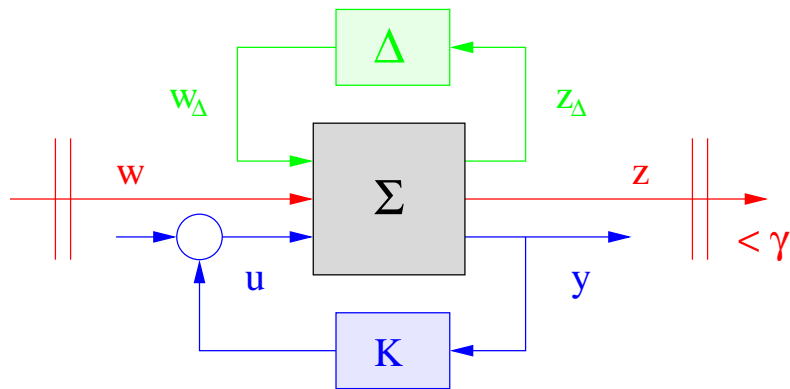

**Linear-Fractional-Transform (LFT):**

$\Delta$  is bloc-diagonal (possibly repeated blocs)

with dissipative elements (norm-bounded, positive real...)

and polytopic elements (interval, ...)

Best known associated scalings

## V1 : Analysis results

→ "quadratic stability" :  $P(\Delta) = P$

→ PDLFs for polytopic models :  $P(\Delta) = \sum \zeta_i P_i$

→ PDLF for LFT :  $P(\Delta) = \begin{bmatrix} I & \Delta_C^T \end{bmatrix} P \begin{bmatrix} I \\ \Delta_C \end{bmatrix} : \Delta_C = (I - \Delta D_{\Delta\Delta})^{-1} \Delta C_{\Delta}$

## Next versions

→ Multi-objective state-feedback & Full-order output-feedback

Nominal system (without uncertainty)

Robust (quadratic stability + PDLF)

Robust & Resilient

→ Descriptor systems

→ Time-delay systems

→ Linear Periodic systems

...